

No.	Reliability test items	Test method	Pass criteria
1	CTF measurement	measuring points by using venire callipers (150mm)	Spec in.
2	leak test	low pressure : power on for 7sec at 0.2~0.3kgf/cm ² high pressure: power on for 7sec at 8.0 ± 0.5kgf/cm ²	no leak.
3	Flow test	check flow at inlet part at 1.5 and 4.5kgf/cm ² for water pressure	Spec in.
4	heat, cold resistance	heat: at 70°C for 48Hr / cold resistance: at -30°C for 48Hr → on room temperature for 30min then functional test	Spec in.
5	Hydraulic test	increase pressure for 5min at 26kgf/cm ² to for 15min to keep 26kgf/cm ² and then decrease for 5min	no damage and leak
6	heat shock test	10times repeat test at -30°C ± 2°C for 0.5Hr and at 70°C ± 2°C for 0.5Hr	Spec in.
7	Burst test	100,000cycle test at 2 on and 6 off	Spec in.
8	Burst test	add more than 60kgf/cm ² within 2min	no damage and leak under lower than 55kgf/cm ²
9	withstand voltage test	voltage : at 1800V for 1 min (leakage current : 0.5mA) more than 100MΩ by measuring metal parts live part and un-live part by using DC500V megohmmeter	Spec in.
10	Torque test	test Torque by using Torque Wrench, more than 65kgf · cm and less than 75kgf · cm	no damage and leak

No.	Code	Revision	Date	Sign	Checked
-		도면 제정	200102	K.J.Y	
△		Adding spark killer	210531	K.J.Y	

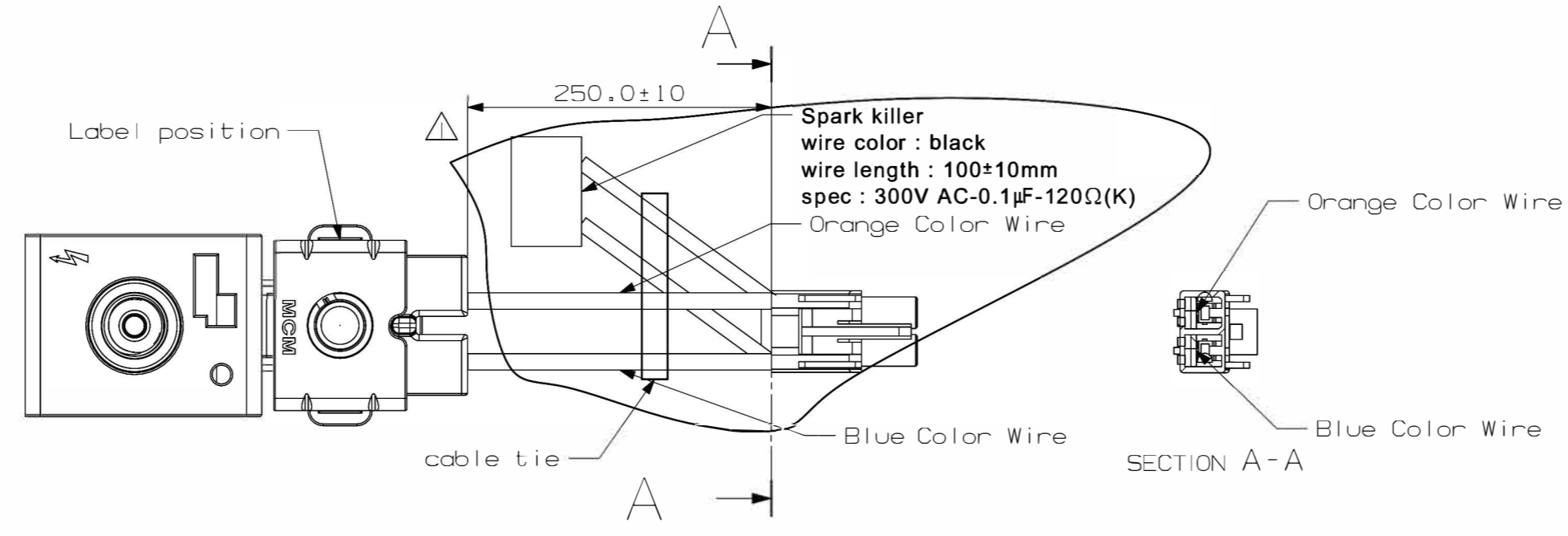

	Model No	color	EA
Housing-Molex connector	35151-0214	Blue	1
Terminal	35746-0110	-	2
Terminal	35746-0310	-	2
T.P.A-Retainer	35150-0290	White	1

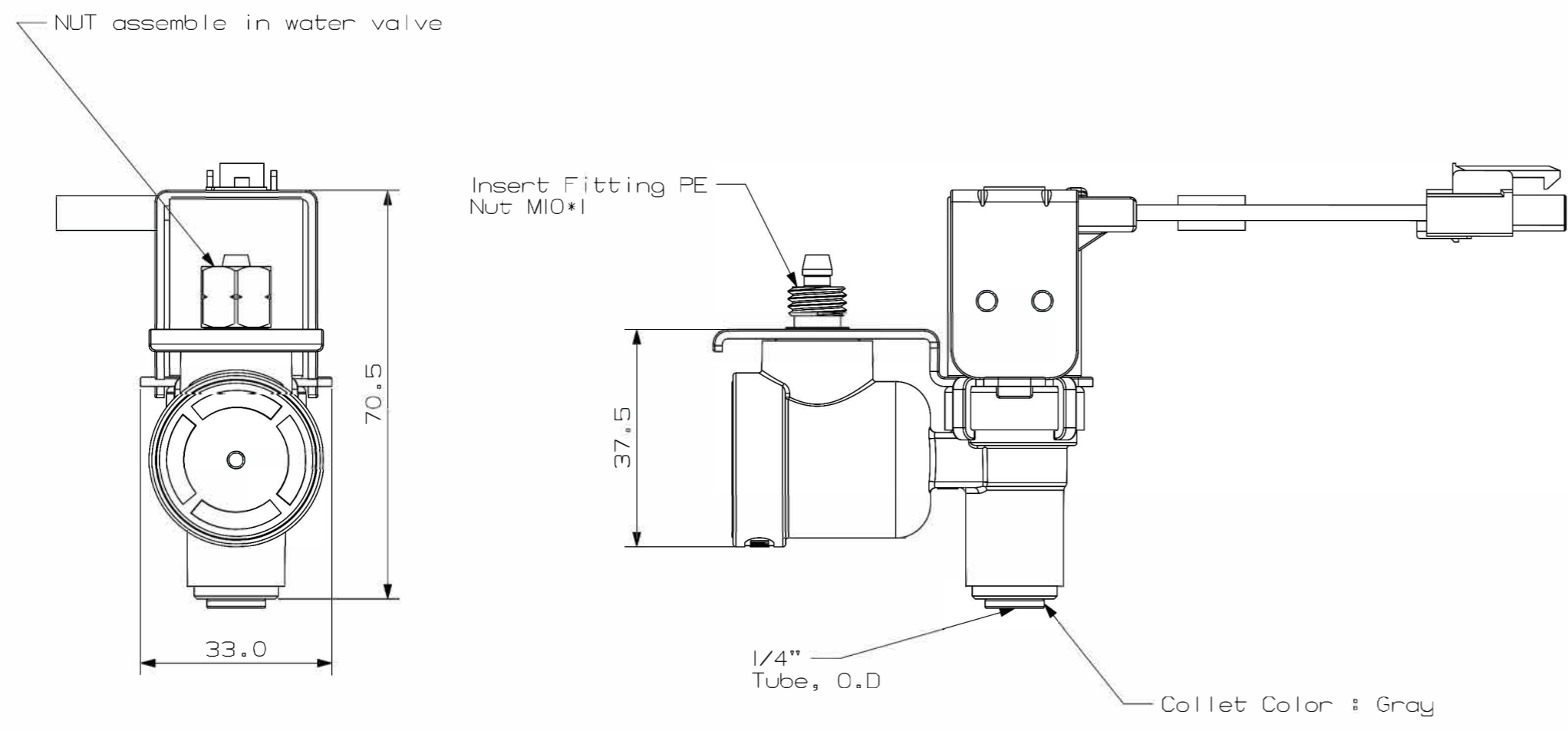

CODE NO(MCM)	D03
Operation	Dish washer
Flow Rate	1.5kgf/cm ² / 6sec
	4.5kgf/cm ² / 6sec
	8.5kgf/cm ² / 6sec
Rated Voltage	AC220V~240V
Rated frequency	50,60[Hz]
Rated current	85 [mA] ↓
Coil Resistance[Ω]	1600Ω ± 10%
Duration of use	intermittent
Water Pressure Extent	1.0 ~ 8.5 kgf/cm ²
BOBBIN Specification	VIOLET

- Note**
1. Rated Voltage/Frequency : 220~240V 85mA at 50/60Hz, 20W
 2. Duty Cycle : 7.5sec on / 15sec off
 3. Fluid temperature : Water 25°C
 4. Ambient Temperature : 40°C
 5. Max Body Pressure : 8.5kgf/cm²
 6. Min/Max Operating Pressure Differential : 1.0 ~ 8.5 kgf/cm²
 7. Coil Class : E
 8. Outlet Type : 1/4"

Sho_jae i Jafar	signature		
Yakhsaran	signature		

Model Name	Yakhsaran_ oneway valve					
Unit	mm	designed	Checked	Approved	Paper Size	A2
Tolerance					SHEET NO	/
Scale	1:1					
(주)MCM	Product No.					